

# SV-140

High Vacuum Rotary Vane Pump

## User Instruction



<b>1. Introduction .....</b>	<b>3</b>
1.1 Safety Precautions	
1.2 Description of SV-140	
<b>2. Installation .....</b>	<b>5</b>
2.1 Unpack and Inspect	
2.2 Location	
2.3 Mechanical connection	
2.3.1 Inlet connection	
2.3.2 Outlet connection	
2.4 Electrical connection	
<b>3. Operation .....</b>	<b>8</b>
3.1 Gas-ballast control	
3.2 Start-up procedure	
3.3 Decontamination of oil	
3.3.1 Checking the oil-level	
3.3.2 Oil change	
3.4 Switching Off/Shut down	
<b>4. Maintenance .....</b>	<b>10</b>
4.1 Safety Guide	
4.2 Maintenance Frequency	
4.3 Maintenance of oil	
4.4 Cleaning the Dirt trap	
4.5 Storage and Disposal	
<b>5. Trouble Shooting .....</b>	<b>15</b>
<b>6. Technical Data .....</b>	<b>16</b>
6.1 Dimensions of SV-140	
6.2 Development figure of SV-140	
6.3 Part List (BOM LIST : SV-140)	
<b>7. Service &amp; Accessories .....</b>	<b>20</b>
7.1 Service kit (Major Kit / Minor Kit)	
7.2 Accessories List	
<b>8. Contact Information .....</b>	<b>22</b>

## 1.1 Safety precautions

Read and follow below instructions before you install and operate the pump.

### \* Notices for safe use :

#### Do not pump corrosive or explosive gases.

As the pump's driving principle, you cannot pump the gases which are explosive when compressed.

The standard SV-140 pump is not designed to prevent corrosion.

In case of pumping strong corrosive gases, please contact our technical sales dept.

#### Do not use pump as compressor

Vacuum pump does not have any special design for withstanding inner pressure.

The accumulated pressure by compressed gases in exhaust line can break pump case, therefore can cause both personal injury and property damage.

#### Do not operate the pumps where explosive processes are involved.

If you need to use explosion-proof motor, please contact our technical sales dept.

The pump must be installed and managed by qualified expert.

Important safety information is highlighted as **WARNING** and **CAUTION** instructions.



### **WARNING**

Indicates procedures that must be strictly observed to prevent personal injury.



### **CAUTION**

Indicates procedures that must be strictly observed to prevent damage to pump or system.

### Additional safety information



Danger of electric shock



Danger of hot surface



Danger of explosion



Danger of cut/crush

## 1.2 Description of SV-140

**SV-140** has been developed to perform the vacuum state before coolant replacement of cars and general air conditioner.

Small sized, lightweight and easy to carry. Simple internal structure makes repairs and maintenance easy.

- |                     |                       |                         |
|---------------------|-----------------------|-------------------------|
| ❶ Inlet end fitting | ❷ Gas ballast control | ❸ Exhaust end fitting   |
| ❹ Oil filling-plug  | ❺ Oil drain-plug      | ❻ Oil level sight glass |
| ❼ Oil case          | ❽ Electric motor      | ❾ Terminal box          |

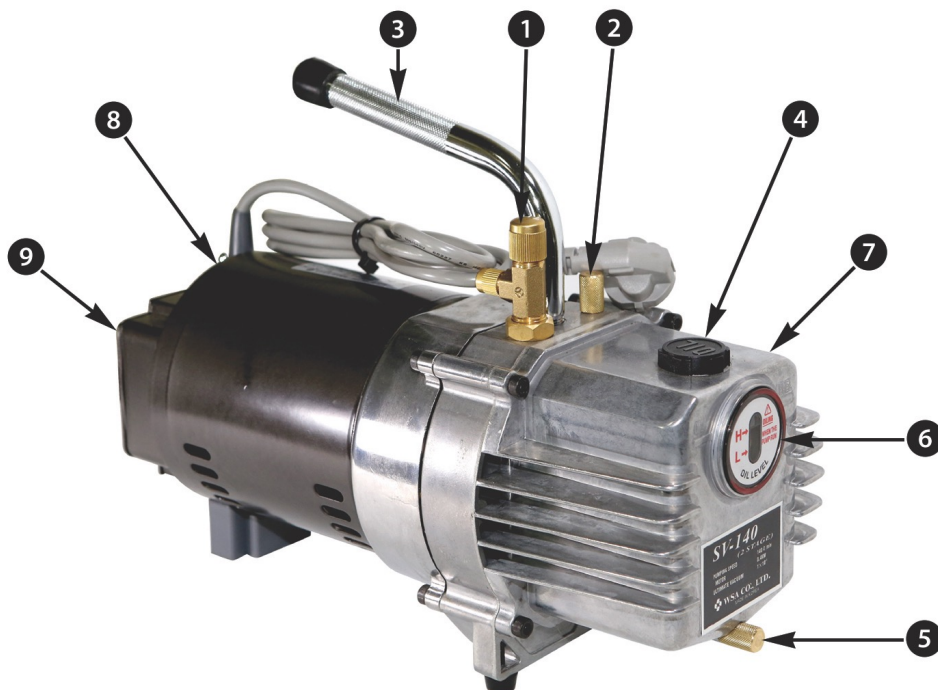

## SV-140

<b>Pumping Speed</b>	140 ℓ/min (8.4m <sup>3</sup> /h, 4.9CFM)	
<b>Ultimate Pressure</b>	Gas Ballast Closed	≤ 5X10 <sup>-3</sup> torr ( 6.7 X 10 <sup>-1</sup> Pa )
	Gas Ballast Open	5X10 <sup>-2</sup> torr ( 6.7 Pa )
<b>Power Input Options</b>	Standard	220VAC 1Φ 50/60Hz
	Options	220/380VAC 3Φ 50/60Hz
	Customer's Request (Voltage, Frequency, Phase)	
<b>Full Load Power</b>	0.4kW (0.5 HP)	
<b>Motor Speed</b>	1,700 rpm	
<b>Inlet and Outlet Options</b>	Standard	Tee / Handle *Change to NW25 available
	Option I	Cross / Handle
	Option II	NW25 + Hose Nipple or PT Nipple
	Option III	User Requested Type
<b>Oil Capacity</b>	600 cc (0.6ℓ)	
<b>Weight</b>	14.7 Kg(1Φ)	
<b>Ambient Temp</b>	7~40°C / 45~104°F	
<b>Overall Dimension (mm)</b>	160(W) X 397(L) X 297(H)	



### **WARNING**

Do not carry out any unauthorized conversions or modifications on the pump

### 2.1 Unpack and Inspect

Remove all packing materials and protective covers.

Leave the inlet and outlet lids on before connection of the pump.

(The pump is supplied filled with oil.)

- ① Check the pump and accessories if they are the same type you have ordered.
- ② Check the oil level contained through the sight glass.
- ③ Check the pump if it has any sign of loose bolts, spilt oil, and broken/loose parts.
- ④ Do not use the pump if it is damaged; notify WSA with your order and serial number.

### 2.2 Location



### **CAUTION**

The pump should be set up on a flat, horizontal surface. Terminal box should not be exposed to excessive moisture.

The pump can be used free-standing on its baseplate.

Locate the pump where you can check the oil level sight-glass and access the controls including oil filling-plug, oil drain-plug, and gas-ballast.

When installing the pump in a closed housing, make sure there is sufficient air circulation.

We use vacuum oil, 'MR-200' as our default vacuum oil and it is recommended to use the pump over 7 °C (45°F)

WSA standard pump is not suited for installation in explosion hazard areas. If you need to apply the pump to such area, please contact us first.

### 2.3 Mechanical connection

Before operating the SV-140 pump, remove the black rubber lid on the end of exhaust handle. Unscrew the tip of inlet Tee(or Cross) before connection.

*\* If inlet/outlet are changed to NW25 flanges..*

Before connecting the WAS pump, remove the shipping seals from the inlet and exhaust connection flanges. (WSA pumps are sealed with white PE seals for domestic and ocean transport and metal blank clamped for air shipment to maintain oil inside)

WSA pumps are shipped with oil contained inside, so take extra care not to spill it

Retain shipping seals in case you need to transfer or store the pump in the future.

Ensure that sealing surfaces are clean and scratch-free prior to assembly.

### 2.3.1 Inlet port Connection

\* **Connection Tip** : To achieve specified pumping speed, make the length of pipeline between vacuum chamber and the pump as short as possible. Also the internal diameter of the pipeline is at least the same as inlet port; the narrow inlet line can reduce pumping speed.

You can protect the pump with applying proper accessories such as separators, filters and cooling traps etc. between vacuum chamber and pump. However, the conductance value of the accessory could cause a reduction in pumping speed.

#### Connection

\* *If inlet/outlet are changed to NW25 flanges.*

Connect the intake and exhaust lines with a clamp and centering each.

- Default : Connect to the NW25 flange supplied on the pump; use the clamp and centering.
- Option 1 : The hose nipple can be provided upon request. Applicable to vacuum hose.  
( $\Phi$  12 OD ,  $\Phi$  16 OD,  $\Phi$  26 OD for NW25 available depending on hose size.)
- Option 2 : Screw nipple can be used. Applicable to screw valves etc.  
(1/4", 3/8", 1/2", 3/4", 1" for NW25 ; available depending on connecting devices.)

Inlet filters can be installed for very dusty applications or pumping condensable vapor.

Valves can be used for isolating the pump from the vacuum system; to maintain vacuum when the pump is switched off. We recommend to install the Angle Valve. (refer section 7.2)

### 2.3.2 Outlet port Connection :



#### **WARNING**

If the exhaust gases from the vacuum pump are harmful to human body, these must be safely lead away and subjected to post-treatment as required

\* **Connection Tip** : Designing the exhaust line lower than the pump can prevent condensate from flowing back into the pump.

Oil vapors can be discharged from the exhaust port in low vacuum section (760 Torr~10 Torr) since the large amount of air is sucked into the vacuum pump. In order to reduce the emission of oil vapors, we recommend the installation of an additional exhaust filter (WSA oil mist trap : refer section 7.2) especially when the oil mist can not be lead out by separate hood or duct system. Contact WSA for the detailed inquiry.

#### Connection

Exhaust connecting options are the same as Inlet Connection (\* with NW25 outlet option)

\* **Connection Tip** : Ensure that the internal diameter of the exhaust line is at least the same as outlet port; the narrow exhaust line can accumulate the inner pressure in the pump and it can damage the pump seals therefore cause oil leaks. The maximum pressure in the oil case must not exceed 1.5 bar (absolute).



#### **CAUTION**

If the temperature of the pump-body exceeds 70°C (158 °F), you must fit suitable guards to prevent contact with hot surfaces.

Depending on the type of application or the kind of pumped media, the corresponding regulations and information sheets must be observed.

## 2.4 Electrical connection



### **WARNING**

ELB(Earth leakage breaker) must be installed to prevent electrical accident. Electrical connections for 3 phase must be done by a qualified electrician.

**If you don't have knowledge of 3 phase power connection, please inquire of WSA. WSA can not be responsible for any trouble caused by electrical connection.**

\* For 1 phase pump, no specific connection process is needed. Simply connect the plug to the power.

### Connection (3 phase)

- ① Open the cover of terminal box. You can see 6 electric cords need to be connected.
- ② For 3 phase motor, 3 external power cords and 1 extra electric cord to earth should be supplied.
- ③ With referring to the diagram on the back of terminal cover, connect the motor to the power.

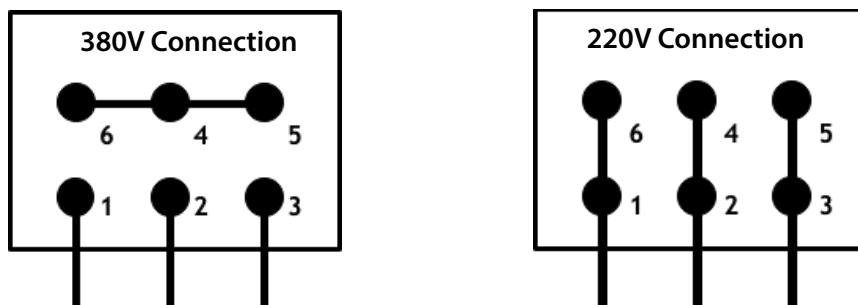

(Fig) Examples of 3 phase power connection

380V at 3 phase : high voltage connection / 220V at 3 phase : low voltage connection.

- ④ After wiring the motor, check its direction of rotation by operating the pump for short time(2~3 sec) before connecting the pump to your vacuum system. If the rotation is the opposite to the direction of the arrow on the motor cap, change the codes from outside ; 1 2 3 (ex. 1 2 3 -> 1 3 2) and check the direction again.

### 3.1 Gas-ballast control

The gas ballast introduces a small amount of air(or inert gas) during the compression stage in order to adjust the saturation pressure of the vapor and it can prevent condensation of vapors in the pump; the condensates cause contamination of the oil.

In general use, it is recommended to use the pump with gas-ballast closed.

GB control closed	GB control open
to achieve ultimate vacuum	to pump high concentrations of condensable vapor
to pump dry gases	to decontaminate the oil

Operating pump with GB control open will lower ultimate vacuum level and raise the temperature of the pump body. Also it will increase the speed of oil loss from the pump.

### 3.2 Start-up procedure



#### **WARNING**

**Never operate the pump with a sealed exhaust line.  
There is the danger of injury.**

Ensure all vacuum connections are completely sealed before switch on the pump.

Operating pump with being exposed to normal pressure in long period of time can cause serious mechanical troubles.

Do not operate the pump with inlet port open. It would overload the pump and cause oil loss.

Never expose any part of the body to the vacuum. It might cause personal injury.

#### **\* In case of Emergency stop or Power failure**

There is no need of a particular procedure to prevent from losing vacuum in case of an emergency stop or power failure.

The oil regulator built inside of the pump prevents Back-Flow of oil when the pump stops.

However, it is more recommended to vent the inlet side of the pump if it stops accidentally.

#### **Procedure**

- ① Check that the pump oil-level is between the H and L marks through the oil-level sight-glass; if it is not, refer to sec 4.3 (Never operate the pump with the oil level below L mark.)
- ② Turn the gas-ballast control to the required position if you pump condensable vapor.
- ③ Switch on the electrical supply to the pump.
- ④ For 3 phase pump, check the direction of rotation of the motor.

When starting-up a pump after prolonged storage period, the actual vacuum level might not be able to reach to the ultimate pressure, specified on the pump. It is generally because of the contamination of the oil inside. Replace with new vacuum oil.



### 3.3 Decontamination of Oil

As the oil is gradually contaminated during operation by dissolved gases and vapors, the degas process is necessary to prevent corrosion of the pump. Allow the pump to continue operating with inlet port closed and gas ballast control open until the oil is free of condensed vapors.

It is recommended to leave the pump being operating in this mode for about 30 min after finishing the process. To attain the ultimate pressure, close the gas ballast after this process.

### 3.4 Switching Off & Shutdown

You can simply switch off to stop the pump, under normal circumstances.

\* When motor is switched off while the gas ballast is open, the system pressure can be risen slowly. (Close the gas ballast to maintain vacuum level.)

If the pump is to be shutdown for an extended period after pumping aggressive or corrosive media or if the pump has to be stored, proceed as follows;

- ① Drain the oil through oil drain-plug.
- ② Add clean oil until the oil-level is at the H mark and let the pump operate for some time.
- ③ Drain the oil again and add clean oil until the oil level is at the H mark.
- ④ Seal the connection ports.



#### **WARNING**

**When pumping harmful substance, take adequate safety precautions.**

## 4.1 Safety Guide



### **WARNING**

Obey the safety instruction given below.  
If you do not, you can cause personal injury and property damage

Allow the pump to cool to a safe temperature before you start maintenance work.



### **WARNING**

Disconnect the electrical connection before disassembling the pump.  
Make absolutely sure that the pump cannot be accidentally started.  
(pull the main plug)

A suitably trained and supervised technician must maintain the pump.

Obey your local and national safety requirements.

If the pump has pumped harmful substances, ascertain the nature of hazard and take adequate safety measures.



### **CAUTION**

When disposing of used oil,  
you must observe the applicable environmental regulation.

When the pump has been pumping corrosive media, we recommend to perform any possibly planned maintenance work immediately in order to prevent corrosion of the pump.

After maintenance is completed and reconnect the power of 3 phase pump,  
recheck the pump rotation direction.

Do not reuse o-ring and seals if they are damaged.

## 4.2 Maintenance Frequency

The plan shown in the below Table details the routine maintenance operations necessary to maintain the pump in normal use.

More frequent maintenance may be required if the pump is used to process corrosive or abrasive gases and vapors; in these circumstances, we recommend that you replace the pump seals every year. If necessary, adjust the maintenance plan according to your experience.

When you maintain the pump, use WAS spares and service kits; there contain all of the components necessary to complete maintenance operations successfully. The Item Numbers of the spares and kits are given in Section 7.1.

### \* WAS provides 2 kinds of Service kits(Repair kits)

'Minor Repair Kit for SV-140' is for the general use for overhaul and consists of various metal and rubber parts. It contains mainly disposable parts which need to be periodically replaced.

'Major Repair Kit for SV-140' contains major parts(ex.vanes) which should be replaced for repair process in addition to all Minor parts.(refer sec 7.1)

**Overhaul** is a process of dismantlement the pump, cleaning all parts and reassembling. It is highly important to improve the performance and elongate lifetime of the pump. WSA recommends users to do overhaul at least every other year.

### Maintenance Frequency

Operation	Frequency
Check the oil-level	Daily
Replace the oil	2,500 operation hours
Inspect and clean the inlet-filter	Every oil change
Clean or replace the gas-ballast o-ring	Every oil change
Clean the motor fan-cover	Yearly
Clean and overhaul the pump	15,000 operation hours
Fit new blades	30,000 operation hours
Test the motor condition	15,000 operation hours

### Oil change Frequency

Application	Frequency (hrs)
High Vacuum in Lab environment, or system seldom exposed to the air	2,500
High Vacuum in manufacturing environment, often exposed to the air	1,200
Vacuum furnace, large gas-exhaust diffusion system, system with booster pump	600
Vacuum drier, vacuum molding, vacuum packing	200
Vacuum distillation, low vacuum tank	120

## 4.3 Maintenance of oil

### 4.3.1 Checking the oil-level

During operation of the pump, the oil level must always remain between marks H and L on the oil-level glass. The amount of oil must be checked and topped up as required.

**Note :** The pump must be switched off before topping up the oil. It is recommended to power off other components connected to pump for safety reason.

If gases or liquids dissolved in the oil result in a deterioration of the ultimate pressure, the oil can be degassed by allowing the pump to run for approx. 30 min. with the intake port closed and the gas ballast valve open.

### 4.3.2 Oil change

For proper operation of the pump, it is essential that the pump has an adequate supply of the correct and clean oil at all times.

Clean vacuum oil is basically odorless and transparent. (MR-200 has pale yellow color.)

As operating pumps, the color of vacuum oil turns from yellow through orange into red brown. This discoloration is caused by gases and foreign materials pumped in and this mixture would impair the vacuum level and damage the interior of pump.

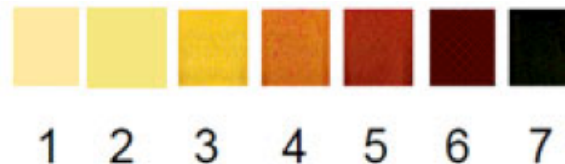

**Change vacuum oil when discoloration is dark yellow to red brown. (4 in above picture.)**

When the color reach 6~7 with deterioration, the interior of pump would be damaged and overhaul process is necessary before operating the pump again.

If the vacuum oil becomes cloudy as milk color, it is caused by moisture flowed in.

In this case, stop the pump and wait until the fluid is divided into two layers; vacuum oil and water. Then drain the water layer completely through oil drain plug.

Design the process so as moisture not to be pumped in and install a cold trap if necessary.

Before and after a prolonged storage, additional change of oil is required.

If the speed of deterioration of oil is too fast, apply dust filter or oil filter to the pump. (refer to sec 7.4 : WMT-250/400)

Contact WSA for further information.



#### **Caution**

Only change the oil after the pump has been switched off and while the pump is still warm..

#### **Procedure**

- ① Remove the oil-drain plug and let the used oil drain into a suitable container.
- ② When the flow of oil slows down, screw the oil-drain plug back in, briefly switch on the pump (max. 10 sec) and then switch it off again. Remove the oil-drain plug once more and drain out the remaining oil.
- ③ Screw the oil-drain plug back in (check the gasket and reinstall a new one if necessary.)
- ④ Remove the oil-fill plug and fill in with fresh oil.
- ⑤ Screw the oil-fill plug back in.

\* Recommended Vacuum oil : **NEOVAC MR 200**



#### **Caution**

We can only guarantee that the pump operates as specified by the technical data if the vacuum oil recommended by us is used.

The ultimate pressure is determined by the saturation vapor pressure, viscosity and solubility of gases of the vacuum oil used.

Use suitable vacuum oil for the pump.

\* MSDS report of MR-200 is available to download on WSA web site.

(<http://www.wsavac.com/eng/sub/products/accessories.asp#>)

NEOVAC MR-200 (Moresco corp.)	
Color (ASTM)	bright yellow (L0.5)
Pour point	-17.5°C
Boiling point	195°C / 0.1 Torr
Flash point	256°C min. (COC)
Viscosity	71.0 (40°C, mm <sup>2</sup> / sec(cSt))
Vapor pressure	1 X 10 <sup>-5</sup> (50°C)

#### 4.4 Cleaning the Dirt Trap

SV-140 pump has dirt trap in the inlet port (\* with NW25 inlet flange option)

; a wire mesh structure which is designed to sieve coarse particles. To keep the pumping speed as specified, the dirt trap should be cleaned up regularly.

Take out the dirt trap from the inlet port and rinse it in a suitable container with solvent

Dry it completely with compressed air.



#### Caution

The cleaning intervals depend on the application. If the pump is exposed to large amounts of abrasive materials, a dust filter should be fitted into the intake line.

Check the status of dirt trap and replace it if damaged.

#### 4.5 Storage and Disposal



#### Caution

Observe the storage temperature: -30~70°C (-22~158°F)  
Storage below -30°C (-22°F) will permanently damage the pump seals.

##### 4.5.1 Storage

The pump should be stored in a dry place preferably at room temperature 20°C (68°F).

All other components and connections to vacuum system must be properly removed and purged the pump with dry nitrogen if possible.

The used oil should be changed to prevent corrosion during the idle period. (refer 3.4)

The inlets and outlets of the pump must be sealed. (Use the seals provided upon delivery.)

The gas ballast switch must be tightly closed and it is recommended to put the pump in a PE bag with silica gel(desiccant) for prolonged storage.

When a pump is put into operation after over one year of storage, standard maintenance should be run on the pump and the oil should also be exchanged.

### 4.5.2 Disposal

Dispose of the pump, the oil and any components removed from the pump safely in accordance with all local and national safety and environmental requirements.

Take particular care with the following:

- Components which have come into contact with the vacuum oil.
- Components which have been contaminated with dangerous process substances.

**\* Do not incinerate fluoroelastomer seals and o-rings. (eg.viton)**

Symptom	Possible cause	Corrective actions
<b>The motor is noisy and does not rotate</b>	voltage of power and connection.	Correct voltage or its connections.
	Any foreign material in the pump.	Remove the substance and/or change oil.
	Motor (Open internal circuit)	Replace open windings.
<b>The pump is noisy and over-heated.</b>	Any foreign material blocks the exhaust valve.	Remove the foreign material.
	Leakage in the system	Fine the part and fix the leakage.
	If leakage valve is opne	Close the valve.
	All valves in the vacuum line	Close if found open.
<b>Vacuum level drops continuously.</b>	Low oil level	Top vacuum oil up.
	Leakage on the connected device	Close the intake and recheck.
	Condensed moisture in oil	Change oil.
	Oil regulator failure	Replace the oil regulator.
	Gas ballast open	Close the gas ballast.
<b>Motor rotates but pump doesn't run.</b>	Worn out coupling	Replace coupling parts.
	Worn out key between motor and pump	Replace the key and set screws
	Any foreign material blocks the pump	Overhaul the pump
<b>The pump fails to start</b>	Status of connected voltage	Align the voltage with motor specification.
	Wiring is malfunctioning	Check and repair wiring.
	Too viscous oil.	Use recommended oil and change if contaminated.
	Oil temperature is below 7°C	Warm up the pump and oil.
	Any foreign material blocked	Overhaul the pump.
	Motor is malfunctioning	Overhaul or replace the motor.
<b>Failure to reach ultimate vacuum</b>	Leakage in the system	Do leak test.
	Measurement range of the gauge	Use suitable gauge for the vacuum level.
	Incorrect way of measuring vacuum	learn how to use the gauge correctly.
	Type of oil or contamination level	Use recommended oil and change it if contaminated.
	Valve failure	Repair or replace the valve
	Insufficient pump capacity	Replace the pump with sufficient capacity.
<b>Pumping speed is too slow</b>	Contamination of dirt trap	Clean or replace the dirt trap.
	Design of piping system.	Make the connected pipes bigger than pump and have minimum length.

6.1 Dimensions of SV-140

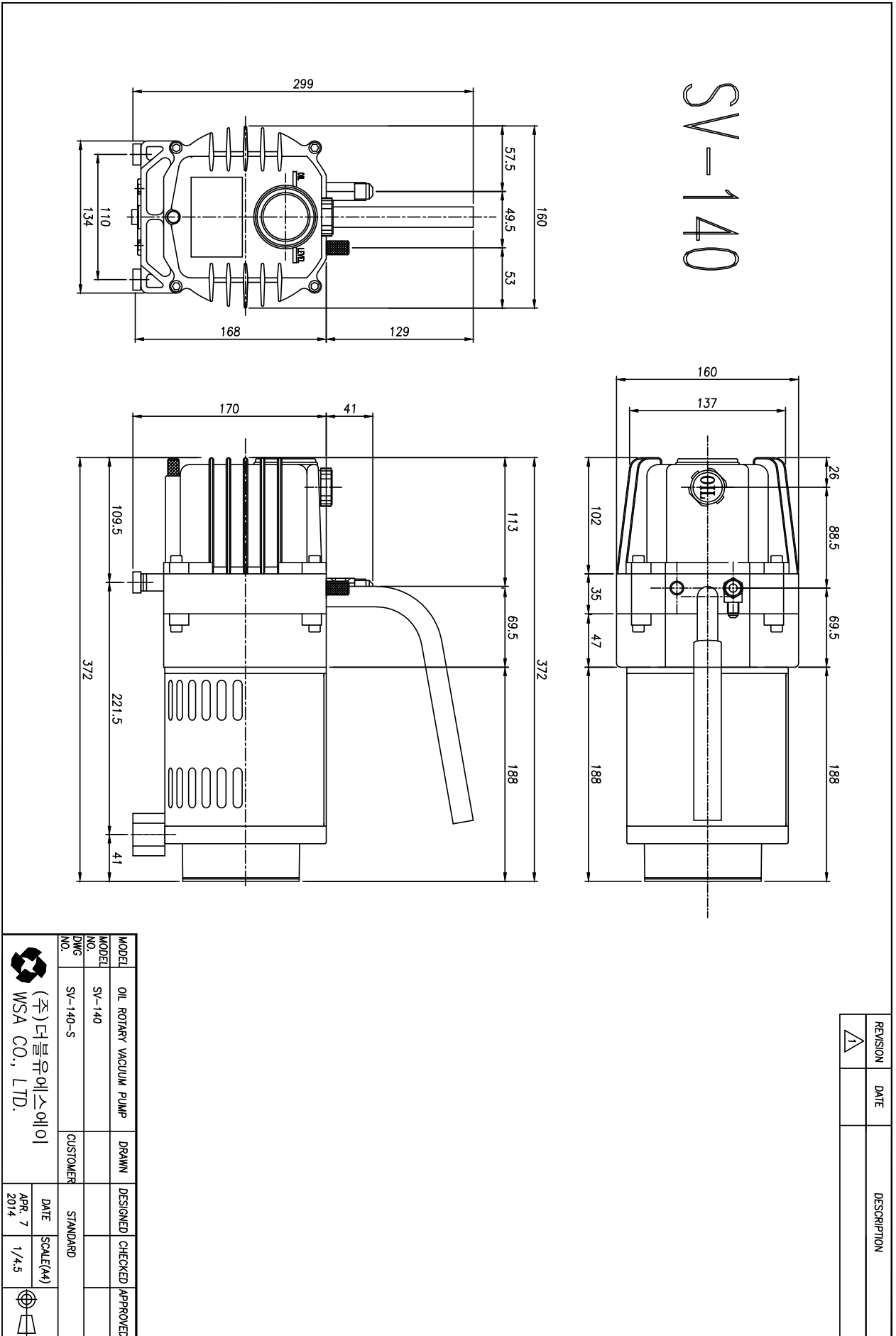

REVISION	DATE	DESCRIPTION
1		

MODEL NO.	OIL ROTARY VACUUM PUMP	DRAWN	DESIGNED	CHECKED	APPROVED
MODEL NO.	SV-140				
DWG NO.	SV-140-S	CUSTOMER	STANDARD		
(주) 더블유에스아이 WSA CO., LTD.		DATE	SCALE(A4)		
		APR. 7 2014	1/4.5		





## Part List (BOM LIST : SV-140)

Part No.	Code No.	Description	Specification	Qty
101	JWME01010010	MOTOR (1PHASE)	1P 220V 400W 50/60Hz	1
102	WPMI01020300	KEY (FOR MOTOR)	5X5X15R	1
103	WPRE01030000	LEG RUBBER	66X37X33 (INJECTION MODELING)	1
104	WPMIM5X30HN	BOLT	M5X30	1
105	WPMIM6X20HN	BOLT	M6X20	4
107	WPMA01070000	MOTOR PLATE	DIECAST	1
110	WPMC01140700	MOTOR PLATE GUIDE PIN	Ø6X13L(BRASS)	2
115	WPMIM6X12HS0	BOLT	M6 X 12(SET SCREW)	2
116	WPMIM5X8HS00	BOLT	M5X8(SET SCREW)	1
119	WPMA00190300	COUPLING FAN	DIECAST(Ø14)	1
122	WPRE01222100	COUPLING JOINT	RUBBER	1
123	WPA01230000	COUPLING	DIECAST(Ø11)	1
201	WPMA02010000	MAIN PLATE(SV-140)	DIECAST	1
203	WPRV02030000	OIL SEAL	Ø22/12 X 7 (TC)	1
215	WPRSP5000000	O-RING	P-5 (SILICON)	1
216	WPMC02160000	GAS BALLAST KNOB	M6 X 12 X 20	1
217	WPMI02170000	SPRING(for check valve)	W0.7XØ10/11.4X40L	1
218	WPRE02180000	ANTI SUCK BACK CHECK VALVE	Ø12 X 15.5	1
219	WPRSAN109000	O-RING	AN-109(SILICON)	1
220	WPRSP1400000	O-RING	P-14(SILICON)	1
221	WPMC02210000	INTAKE FLANGE NUT	NPS 3/8"18 (Acidification)	1
222	WPMC02220000	INTAKE FLANGE	3/8"x 7/16"(TEE)	1
223	WPRNAN110000	O-RING	AN-110	1
224	WPMC02240000	INTAKE FLANGE CAP	3/8" (TEE)	1
225	WPRNAN106000	O-RING	AN-106	1
226	WPMC02260000	INTAKE FLANGE CAP	7/16" (TEE)	1
227	WPRSAN119000	O-RING	AN-119(SILICON)	1
228	WPRS00220000	O-RING	131.6 X 104 X 2.6(SILICON)	1
229	WPRSP6000000	O-RING	P-6(SILICON)	1
237	WPMIM5X15HN	BOLT	M5X15	2
238	WPRE02380000	LEG RUBBER (FOR BODY)	Ø19/18 X Ø5 X 7.5	2
239	WPMI02390000	EXHAUST & HANDLE	Ø17.5 x 230	1
240	WPRE02400000	HANDLE END CAP	Ø16(PVC soft)	1
241	WPMS02410000	OIL BAFFLE	82 X 92 X 0.7t(SUS)	1
242	WPMIM6X8HN0	BOLT	M6 X 8	1
301	WPMI03010000	1ST STAGE STATOR(40T)	CAST IRON	1
302	WPMC03020000	BUSH(FOR 1ST & BODY	Ø12/18/22 X 11/14.5t	1
303	WPMI03030000	1ST, BODY SEPARATOR(11T)	SMF4030	1
304	WPMI03040000	1ST GUIDE PIN	Ø6 X 16L(BRASS)	2
305	WPRV03050000	1ST STAGE VALVE(BROWN)	20 X 54 X 2t(VITON)	1
306	WPMC03060000	TAPER PIN	Ø3.5 X Ø2.9 X 6.0	1
307	WPMC03070000	1ST & 2ND VALVE SPACER	Ø8/5 X 2	1
308	WPMI03080000	1ST VALVE SPRING	20 X 51.5 X 0.3t	1
309	WPMSW5N0000	WASHER	Ø5(SUS FLAT)	1
310	WPMIM5X8HN0	BOLT	M5 X 8	1
401	WPMI04010000	ROTOR ASSEMBLY	SMF4030	1
406	WPMI04060000	2ND GUDIE PIN	Ø6 X 23L(BRASS)	2
407	WPMC04070000	SPACER	Ø6.5/14X13T	1

Part No.	Code No.	Description	Specification	Qty
411	WPME0411000	1ST STAGE BLADE	17.4 X 40 X 6t(43x40.2x6.2t)	2
414	WPME0414000	2ND STAGE BLADE	17.4X13X6T(43x13.2x6.2t)	2
501	WPMIO501000	2ND STAGE STATOR(13T)	SMF4030	1
503	WPRV0503000	2ND STAGE VALVE (BROWN)	12.5X54X2T (VITON)	1
505	WPMC0307000	1ST & 2ND VALVE SPACER	Ø8/5 X 2	1
506	WPMIO506000	2ND STAGE VALVE SPRING 1	10 X 51 X 0.3t	1
507	WPMIO507000	2ND STAGE VALVE SPRING 2	10 X 29 X 0.3t	1
508	WPMIM5X8HNO	BOLT	M5 X 8	1
601	WPMIO601000	END PLATE(6T)	SMF4030	1
607	WPMIM6X90HN	BOLT	M6X90	4
608	WPMIW6S0000	WASHER	Ø6 (SPRING)	4
701	WPMA0701000	OIL BOX	DIECAST	1
705	WPRSP440000	O-RING(for oil window)	P-44(SILICON)	1
706	WPMA070600	OIL LEVEL WINDOW FIXING	Ø48 X 6T(DIECAST)	1
707	WPME0707000	OIL LEVEL WINDOW	M40 X 19.5(PC)	1
708	WPPA0708000	OIL LEVEL MARK	STICKER	1
709	WPMC0709000	OIL DRAIN PLUG	M6 X 12 X 20	1
710	WPRSP500000	O-RING(oil drain plug)	P-5	1
711	WPRSAN118000	O-RING(for oil filling plug)	AN-118(SILICON)	1
712	WPRE07122100	OIL FILLING PLUG	M24	1
716	WPMIM6X20HN	BOLT	M6 X 20	4
717	WPMA0717000	NAME PLATE(BASIC)	STICKER	1
718	WPPA0718000	SERIAL NO STICKER	STICKER	1

## 7.1 Service Kits (Major / Minor) : SV-140

No	C/N	Description	Qty	Standard	Remarks
1	203	OIL SEAL	1	Ø22/12 X 7(TC)	Minor and Major
2	215	O-RING(for G/B knob)	1	P-5(silicon)	Minor and Major
3	219	O-RING(for intake flange)	1	AN-109(SILICON)	Minor and Major
4	220	O-RING(for intake flange)	1	P-14(silicon)	Minor and Major
5	227	O-RING(for body)	1	AN-119(SILICON)	Minor and Major
6	228	O-RING(for body)	1	131.6 X 104 X 2.6(SILICON)	Minor and Major
7	229	O-RING(for body)	1	P-6(SILICON)	Minor and Major
8	305	1ST STAGE VALVE(BROWN)	1	20 X 54 X 2t(VITON)	Minor and Major
9	503	2ND STAGE VALVE(BROWN)	1	12.5 X 54 X 2t(VITON)	Minor and Major
10	705	O-RING(for oil window)	1	P-44(SILICON)	Minor and Major
11	707	OIL LEVEL WINDOW	1	M40 X 19.5(PC)	Minor and Major
12	710	O-RING(oil drain plug)	1	P-5(silicon)	Minor and Major
13	711	O-RING(for oil filling plug)	1	AN-118(SILICON)	Minor and Major
<b>Minor Kit (No.1~13)</b>					
14	217	SPRING(for check valve)	1	W0.7 X Ø10/11.4 X 40L	Major only
15	218	Check Valve	1	Ø12 X 15.5	Major only
16	308	1ST VALVE SPRING	1	20 X 51.5 X 0.3t	Major only
17	411	1ST STAGE BLADE	2	20 X 51.5 X 0.3t	Major only
<b>Major Kit (No.1~17)</b>					

## 7.2 Accessories List

Product	Item	Specificaton	Remark
Oil Mist Trap	WOF-150(PC)	NW25	Outlet Filter
	WOF-150(Metal)		
	WOF-250(Metal)		
	WOF-250(PA)	NW40	
	WOF-350(Metal)		
	WOF-450(Metal)		
WSA Material Filter (Dust Filter)	WMT-250	NW25	Inlet Filter
	WMT-400	NW40	
Clamp	Clamp	NW16 / NW25 / NW40 / NW50	In/Oulet pipe connection
Centering	Centering - NBR	NW16 / NW25 / NW40 / NW50	Clamp fitting sealing
	Centering - Viton		
Hose Nipple	Hose Nipple	NW25 - $\Phi$ 12 / $\Phi$ 16 / $\Phi$ 26 , NW40 - $\Phi$ 36	for vaccum hose fitting
PT Nipple	PT Nipple	1/4", 3/8", 1/2", 3/4", 1" for NW25	Screw Nipple
Reducer	Reducer	VG50-NW25 / VG150-NW25 NW25-NW16/NW40-NW25/NW50-NW40	Adjust In/outlet size
Angle Valve	Air single bellows	NW25 / NW40	
	Air single o-ring		
	Air double bellows		
	Air double o-ring		
	Manual bellows		
	Manual o-ring		
Auto Vent Velve	Auto Vent Velve	NW25 / NW40	
Sol Valve	Sol Valve	NW25 / NW40	
Z-Line Valve	Manual o-ring	NW25 / NW40	
	Manual bellows		
Vacuum Hose	Vacuum Hose	$\Phi$ 8 / $\Phi$ 13 / $\Phi$ 20 / $\Phi$ 32	Soft rubber hose
Bellows	Bellows	NW16 / NW25 / NW40 / NW50	Metal pipe to suspend
Blank	Blank	NW16 / NW25 / NW40 / NW50	Metal lid to end fitting
Cross	Cross	NW16 / NW25 / NW40 / NW50	Cross Fitting
Elbow	Elbow	NW16 / NW25 / NW40 / NW50	Elbow Fitting
Tee	Tee	NW16 / NW25 / NW40 / NW50	T-shpae Fitting
Welding Flange	Welding Flange	NW16/NW25/NW40/NW50-15mm/30mm	For welding

### For Technical Support and Sales Inquiry :

**WSA Co.,Ltd. (HQ)**

TEL : +82 31 426 8536

FAX : +82 31 426 8539

Email : [webmaster@wsavac.com](mailto:webmaster@wsavac.com)

URL : <http://www.wsavac.com>

Address : 869, KWANYANG-DONG, DONGAN-GU,  
ANYANG-SI, GYEONGGI-DO, 431-060  
SOUTH KOREA

Our technical sales department is available for any inquiry about WSA products.